

CAMBS GLASS LTD TEL - +44 (0)1638 640 038
 UNIT 3 SWAN LANE FAX - +44 (0)1638 667 600
 EXNING
 NEWMARKET E-MAIL - info@cambsglass.co.uk
 CB8 7EN WEBSITE - www.cambsglass.co.uk

All Cambs glass drawings and designs are copyright and thus the sole property of Cambs Glass Ltd. All design information it contains are private and confidential, strictly forbidding it being copied, exhibited or communicated (without written consent) to third parties for any purpose other than that for which it has been issued.
 It is Cambs Glass policy to continually develop and improve our designs and products, therefore reserve the right to modify or change the detail design at our discretion and without notice.

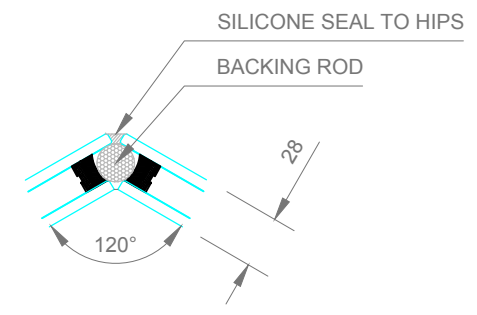

SECTION B-B
SCALE NTS(A3)

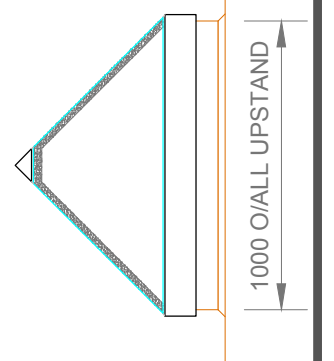
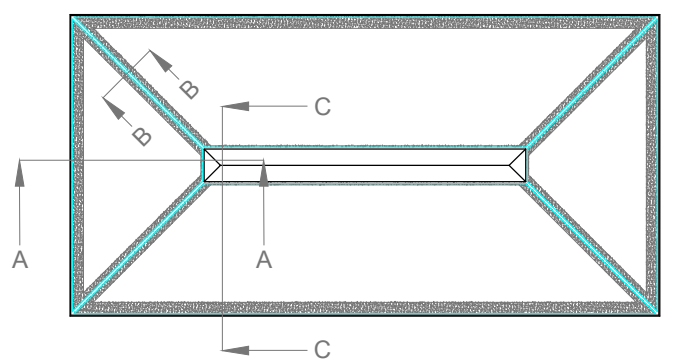
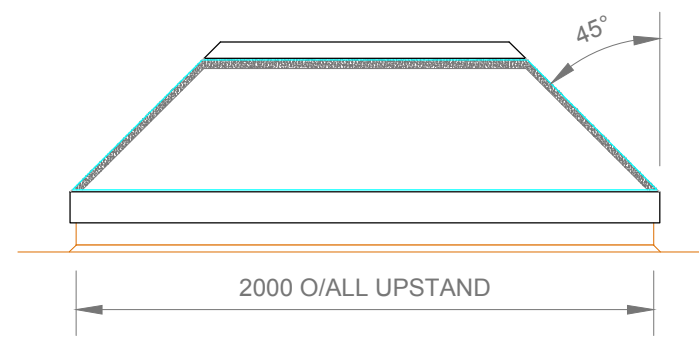

PLAN AND ELEVATION
SCALE NTS(A3)

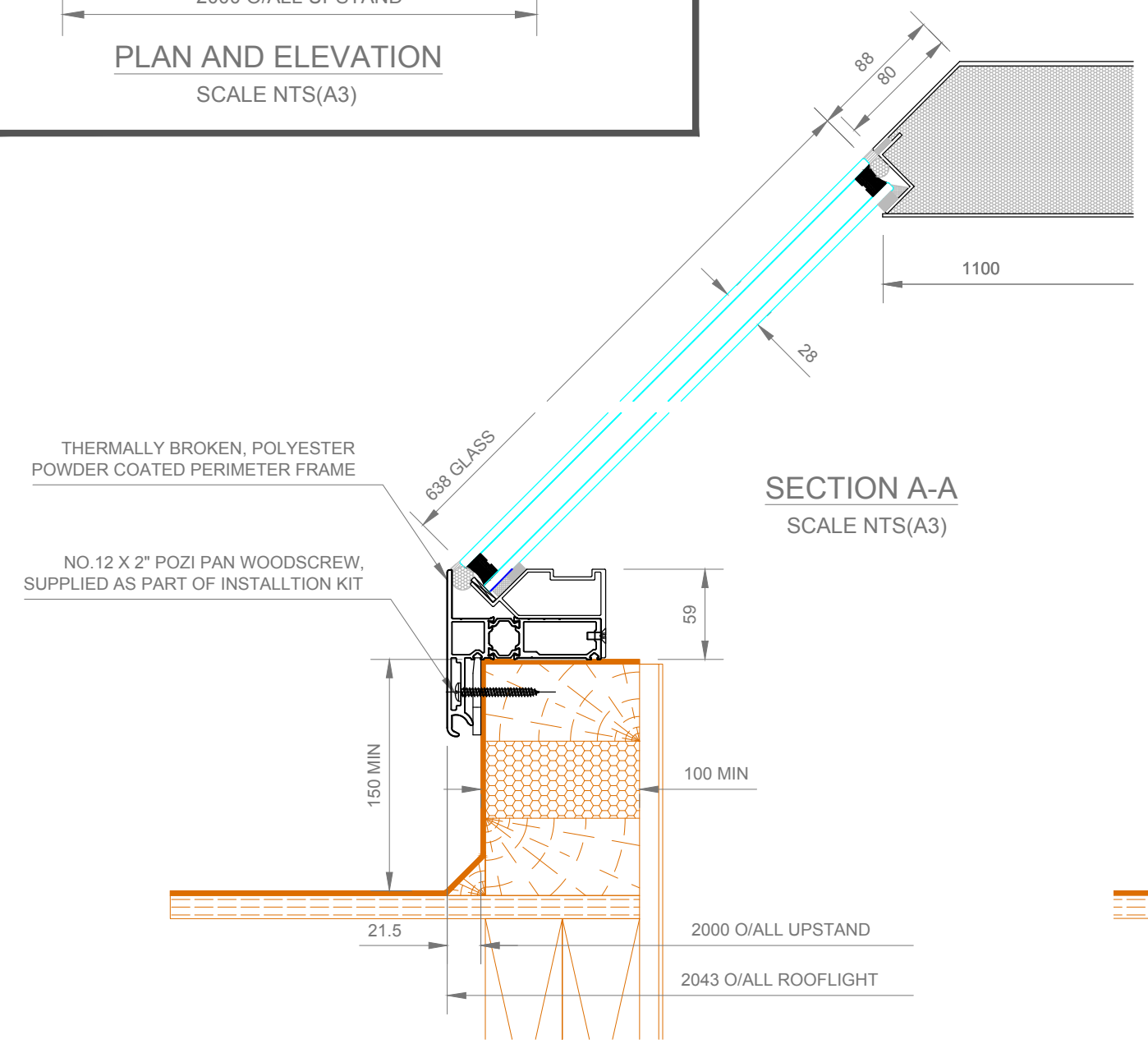

SECTION A-A
SCALE NTS(A3)

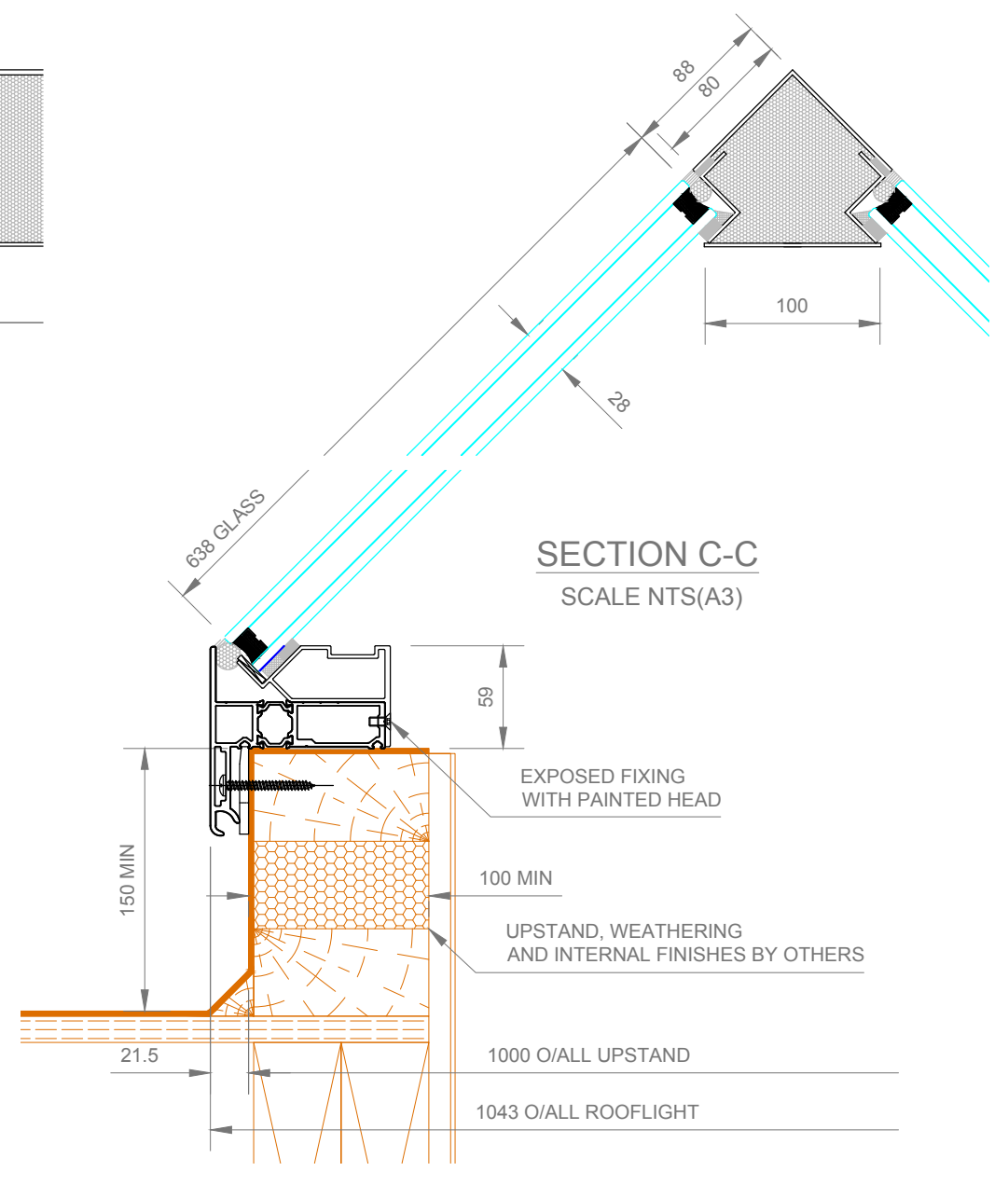

SECTION C-C
SCALE NTS(A3)

SPECIFICATION

GLASS SPECIFICATION

6mm CLEAR TOUGHENED LOW E
 16mm BLACK SILICONE SEALED SPACER
 6mm CLEAR TOUGHENED OUTER
 ALL GLASS CONFORMING TO IMPACT RESISTANCE AND BREAKAGE CHARACTERISTICS OF BS6206, WITH ALL GLASS UNITS FABRICATED TO BS5713A AND IN ACCORDANCE WITH BS6262

FINISH SPECIFICATION

POLYESTER POWER COATED RAL 7015 MATT EXT / 9010 MATT INT
 POLYESTER POWER COATING, MINIMUM THICKNESS OF 40 MICRONS.

FRAMEWORK SPECIFICATION

ALL ALUMINIUM EXTRUSIONS TO COMPLY WITH BS1474 AND ALUMINIUM SHEET/PLATE TO BS EN 485, 515 & 573. TYPICALLY PROVIDED IN GRADES 6063 & 6082 (EXTRUSIONS) AND S1CH4 & NS4 (SHEET/PLATE). ALL MILD STEEL COMPONENTS TO BE GALVANISED, ZINC COATED OR RED OXIDE PRIMED PRIOR TO FINISH APPLICATION. ALL STAINLESS STEEL COMPONENTS PROVIDED IN GRADE 304 STAINLESS STEEL UNLESS OTHERWISE NOTED. EXTREME ENVIRONMENTS (INC. MARINE) MUST BE HIGHLIGHTED AT SALES OR DESIGN STAGE.

HARDWARE SPECIFICATION

ALL HARDWARE TO BE SCHEDULED FOR PURPOSE, TAKING INTO CONSIDERATION BOTH ENVIRONMENT AND BI-METALLIC REACTIONS. FASTENERS TYPICALLY SUPPLIED IN GRADE A2 & A4 STAINLESS STEEL. ALL GASKETS AND TAPES TO HAVE A COMPOSITION SUITABLE FOR CLIMATIC CONDITIONS AND UV LIGHT IN ACCORDANCE WITH BS4255. SILICONES TO BE SUPPLIED AS LOW MODULUS, NEUTRAL CURE (TYPE A) IN ACCORDANCE WITH BS5889 UNLESS OTHERWISE NOTED.

UPSTAND/APERTURE SPECIFICATION

ALL UPSTANDS/APERTURES TO BE PROVIDED WITHIN A TOLERANCE OF +/- 10mm TO THE DIMENSIONS STATED (TAKING INTO CONSIDERATION THE SQUARENESS OF THE STRUCTURE). ANY DIFFERING TOLERANCE REQUIREMENTS AS INDICATED. ALL UPSTANDS/APERTURES TO BE SUITABLE FOR SEALING WHERE INDICATED AND STRUCTURALLY ADEQUATE FOR THE LOADS IMPOSED.

CLIENT
STANDARD PRODUCTS

CONTRACT

JOB REF	
ISSUE A NEW DRAWING ISSUE	NAME AME DATE 10/04/15
ISSUE B	NAME DATE
ISSUE C	NAME DATE
ISSUE D	NAME DATE

PLAN VIEW AND ELEVATIONS FOR 1 No. STANDARD PYRAMID ROOFLIGHT 2000 x 1000

DRG No. CG-PR-004 ISS. A